

Pyxis[®]

ST-765SS Series User Manual

Inline Stainless Steel Oxidizer + pH Sensor



Pyxis Lab[®] Inc.

1729 Majestic Drive (Suite 5)

Lafayette, Colorado 80026

+1 (866) 203-8397

www.pyxis-lab.com

ST-765SS Series

pH + Free Chlorine / Chlorine Dioxide

Multiparameter Sensor

Operation Manual

September 7, 2022

Rev. 2.2

Pyxis Lab, Inc.

1729 Majestic Dr. Suite 5

Lafayette, CO 80026

USA www.pyxis-lab.com

Table of Contents

1	Introducing the Pyxis ST-765SS Series Sensors.....	3
1.1	Features of the Pyxis ST-765SS Series.....	3
1.2	Specifications	4
1.3	Unpacking the Pyxis ST-765SS	4
1.4	Standard Accessories	5
1.5	Optional Accessories	5
2	Installation.....	5
3	Quick 4-20mA Start Up.....	9
4	Calibration and Diagnosis.....	9
4.1	Calibration and Diagnosis by uPyxis Mobile App.....	9
4.1.1	Free Chlorine/ Chlorine Dioxide Calibration	11
4.1.1.1	Single Point Calibration Procedure	11
4.1.1.2	Two-Point Calibration Procedure.....	12
4.1.2	pH Calibration	13
4.1.3	4-20mA Span	14
4.1.4	Diagnosis	14
4.2	Calibration and Diagnosis by uPyxis Desktop App.....	15
4.2.1	Free Chlorine/ Chlorine Dioxide Calibration	18
4.2.1.1	Single Point Calibration Procedure	18
4.2.1.2	Two-Point Calibration Procedure.....	18
4.2.2	pH Calibration	19
4.2.3	4-20mA Span	21
4.2.4	Diagnosis	22
4.3	Calibration on the Controller	23
5	Modbus RTU	23
6	Sensor Cleaning and Maintenance	24
6.1	Other Common Troubleshooting Issues.....	24
7	Replacing pH and Free-chlorine Electrode Head	24
8	Contact Us.....	24

Warranty Information

Confidentiality

The information contained in this manual may be confidential and proprietary and is the property of Pyxis Lab, Inc. Information disclosed herein shall not be used to manufacture, construct, or otherwise reproduce the goods described. Information disclosed herein shall not be disclosed to others or made public in any manner without the express written consent of Pyxis Lab, Inc.

Standard Limited Warranty

Pyxis Lab warrants its products for defects in materials and workmanship. Pyxis Lab will, at its option, repair or replace instrument components that prove to be defective with new or remanufactured components (i.e., equivalent to new). The warranty set forth is exclusive and no other warranty, whether written or oral, is expressed or implied.

Warranty Term

The Pyxis warranty term for the ST-765SS Series sensor body is thirteen (13) months from original shipment from Pyxis. The Pyxis warranty term for the EH-765 (electrode reference head) installed on the ST-765SS Series sensor body is six (6) months from original shipment from Pyxis. In no event shall the standard limited warranty coverage extend beyond this timeline from original shipment date.

Warranty Service

Damaged or dysfunctional instruments may be returned to Pyxis for repair or replacement. In some instances, replacement instruments may be available for short duration loan or lease.

Pyxis warrants that any labor services provided shall conform to the reasonable standards of technical competency and performance effective at the time of delivery. All service interventions are to be reviewed and authorized as correct and complete at the completion of the service by a customer representative, or designate. Pyxis warrants these services for 30 days after the authorization and will correct any qualifying deficiency in labor provided that the labor service deficiency is exactly related to the originating event. No other remedy, other than the provision of labor services, may be applicable.

Repair components (parts and materials), but not consumables, provided during a repair, or purchased individually, are warranted for 90 days ex-works for materials and workmanship. In no event will the incorporation of a warranted repair component into an instrument extend the whole instrument's warranty beyond its original term.

Warranty Shipping

A Repair Authorization (RA) Number must be obtained from Pyxis Technical Support before any product can be returned to the factory. Pyxis will pay freight charges to ship replacement or repaired products to the customer. The customer shall pay freight charges for returning products to Pyxis. Any product returned to the factory without an RA number will be returned to the customer. To receive an RMA you can generate a request on our website at <https://pyxis-lab.com/request-tech-support/>.

Pyxis Technical Support

Contact Pyxis Technical Support at +1 (866) 203-8397, service@pyxis-lab.com, or by filling out a request for support at <https://pyxis-lab.com/request-tech-support/>.

1 Introducing the Pyxis ST-765SS Series Sensors

Description

The Pyxis ST-765SS Series are stainless steel multi-parameter membrane-less sensors based on unique electrochemical principles to determine free chlorine or chlorine dioxide and pH content in water. These sensors incorporate Pyxis' advanced technology in the field of bare-gold electrochemical detection. The ST-765SS-FLC sensor integrates free chlorine, plus pH measurement while the ST-765SS- CLO integrates chlorine dioxide plus pH measurement. Both can perform temperature and pH compensation for the measurement of free chlorine or chlorine dioxide based on conditions present in the application of use. This unique internal compensation results in a highly accurate oxidizer measurement consistent with DPD wet chemistry methodology as high as a pH of 9.0 and is compliant with USEPA – 334.0 guidelines.

The ST-765SS series sensors offer a replaceable, front loading reference electrode assembly that has been independently developed by Pyxis Lab eliminating the shortcomings associated with membranes and gel replacement while offering reduced polarization time on startup. The flat front-end design of the ST-765SS series makes this platform less prone to contamination or fouling and is easy to clean. The ST-765SS series sensor body is composed of 304 stainless steel and is well suited for aggressive environments.

The ST-765SS series sensors offer 2x 4-20mA and RS-485 Modbus outputs and is Bluetooth 5.0 enabled when used in conjunction with the MA-CR Bluetooth Adapter. The world's first four-electrode composite sensor that provides three measured parameters including free chlorine or chlorine dioxide, pH and temperature with one sensor RS-485 Modbus output. ST-765SS is the best choice for potable water, secondary water supply, domestic water and other clean water applications.



ST-765SS Series
Free Chlorine + pH Sensor
Chlorine Dioxide + pH Sensor

1.1 Features of the Pyxis ST-765SS Series

Key Features

- Real-Time pH + FCI (0-5ppm) or ClO₂ (0-5ppm) Detection
- Dual 4-20mA Outputs (FCI or ClO₂ + pH) and RS-485
- Bluetooth Enabled with MA-CR Adapter for Wireless uPyxis Calibration
- Integrated RTD & pH Compensation to pH 9.0 of the Oxidizer Value
- Replaceable EH-765 Reference Electrode Assembly – Simple Maintenance



EH-765
Replacement Electrode
for ST-765SS Series

1.2 Specifications

Specifications are subject to change without notice. Contact Pyxis (service@pyxis-lab.com) for an updated specification list.

Item	ST-765SS-FCL	ST-765SS-CLO
P/N	53607	53608
Sensor Body Material	304SS	
Oxidizer Range	0.00-5.00 ppm FCl ₂ / ClO ₂ (auto-range)	
Oxidizer Precision	± 0.01mg/L or 1% of the value w/pH compensation up to 9.0+	
pH Range	0-14	
pH Precision	±0.01 pH	
FR-50 Sample Inlet Pressure	7.25 – 30 psi (0.05 – 0.2MPa)	
FR-50 Installation	FR-50 Self-Regulating Flow Reservoir w/Rotameter & PRV - Included	
FR-50 Minimum Flow Rate	200 mL/minute	
FR-50 Maximum Flow Rate	400 mL/minute	
FR-50 Sample Inlet	¼ - inch OD	
FR-50 Sample Outlet	20mm - To Drain	
FR-50 Overflow Outlet	20mm - To Drain	
FR-50 Sewage Drain Outlet	½ - inch NPT	
Power Supply	22 – 26VDC, Power Consumption 2W	
Storage Temperature	-7 °C – 60 °C (20 – 140 °F)	
Outputs	Dual Isolated 4 – 20 mA Analog Outputs + Isolated RS-485 Digital Output	
Dimension (L x D)	Length 8.3 inch (210.8 mm), body diameter 1.4 Inch (35.6 mm)	
Weight	530 g (1.16lbs)	
Maximum Sensor Pressure	100 psi (6.9 Bar) – Sensor Only	
Operating Temperature	4 °C – 49 °C (40 – 120 °F)	
Wet Material	UPVC	
Rating	IP67, Fully Dustproof & Waterproof	
Selectivity	Non-Selective, cross sensitive to other oxidizing species	
Compliance	EPA 334.0 / ISO 7393	
Regulation	CE Marked / RoHS	
Cables Included	MA-4.9CR Cable (8-Pin Adapters – 4.9ft) MA-1.5CR Cable (8 Pin Adapter / Flying Leads – 1.5ft)	
Typical Electrode Service Life	2 Years	
Electrode Warranty	6 Months	
Sensor Body Warranty	13 Months	

1.3 Unpacking the Pyxis ST-765SS

Remove the instrument and accessories from the shipping container and inspect each item for any damage that may have occurred during shipping. Verify that all items listed on the packing slip are included. If any items are missing or damaged, please contact Pyxis Customer Service at service@pyxis-lab.com.

1.4 Standard Accessories

- One **ST-765SS** Series sensor
- One **FR-50 Flow Reservoir Assembly** with Rotameter and PRV
- One **MA.4.9CR** – (Standard Cable Male-Female 8-Pin Adapters – 4.9ft)
- One **MA-1.5CR** – (Flying Lead Cable Female/Flying Lead 8-Pin Adapter – 1.5ft)
- The full instrument manual is available for download at [ST-765SS Series Free Chlorine or Chlorine Dioxide Sensors | Pyxis Lab® \(pyxis-lab.com\)](http://pyxis-lab.com)

1.5 Optional Accessories

The following optional accessories can be purchased via your Regional Sales contact or Pyxis Customer Service at order@pyxis-lab.com.

Accessory Name	Item Number
ST-765SS-FCL (Replacement Sensor Only)	53607-NFR
ST-765SS-CLO (Replacement Sensor Only)	53608-NFR
MA-CR (Bluetooth Adapter for sue with Laptop or Desktop for uPyxis)	MA-CR
NA-NEB (USB Bluetooth Adapter for use with Laptop or Desktop for uPyxis)	NA-NEB
MA-50CR (Extension Cable-50 feet)	50743
pH 4-7-10 Combination Pack – Refence Standard Solutions (500ml/each)	57007
Zero Chlorine Calibration Standard Solution (Free Chlorine)	21022
EH-765 (Replacement Reference Electrode Head for ST-765SS Series)	53601
UC-50 (Display + Data Logging Terminal)	43007
FR-50 (Replacement Flow Reservoir)	50700-A01

2 Installation

ST-765SS Series Dimensions (mm) as shown in *Figure 1*.

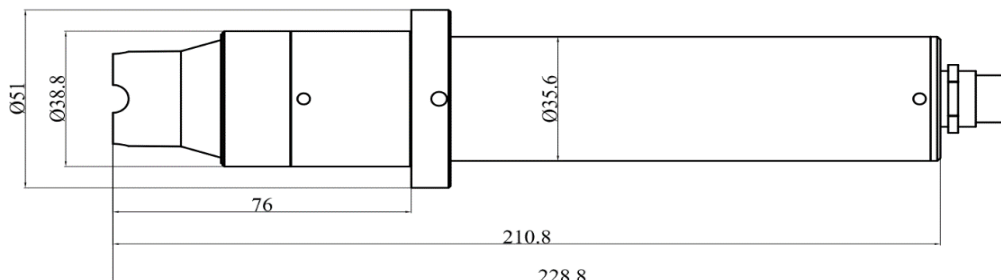

Figure 1. Dimension of the ST-765SS (mm)

FR-50 Flow Reservoir Diagram as shown in *Figure 2*.

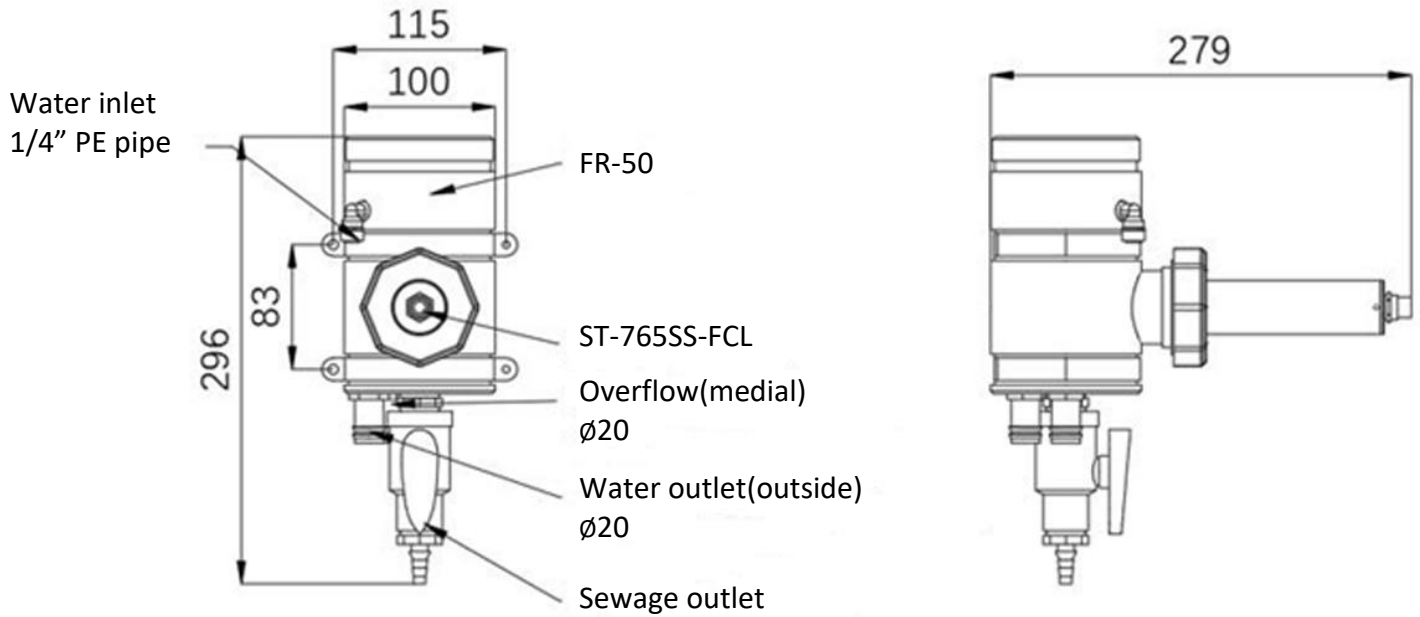

Figure 2. FR-50 Flow Reservoir Diagram for ST-765SS Series Sensors

FR-50 Flow Reservoir Installation Structure as shown in *Figure 2A*.

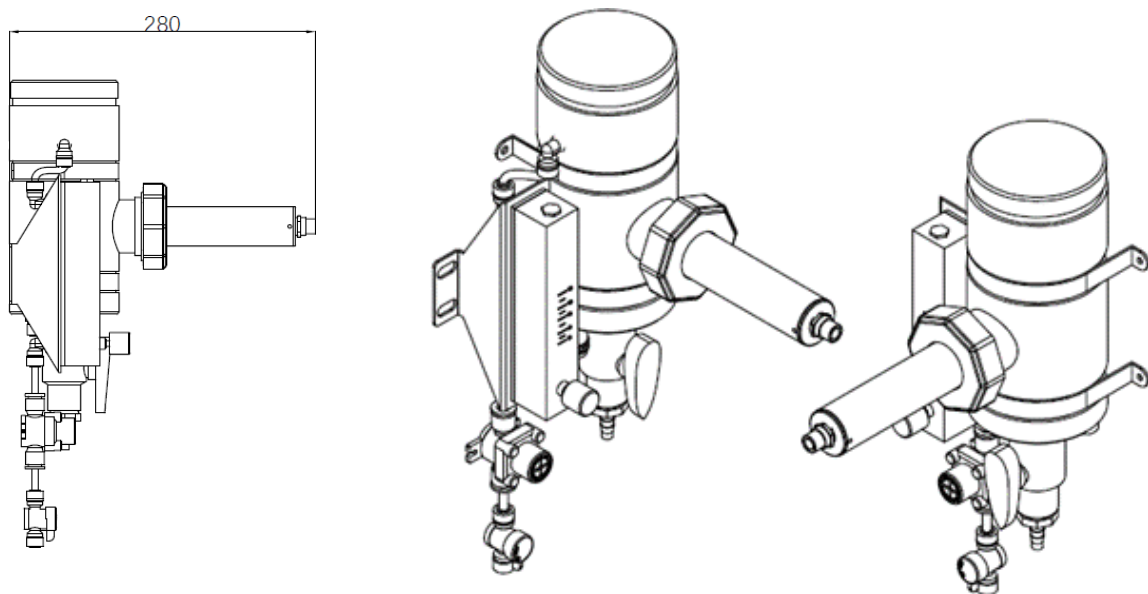

Figure 3 Flow Cell diagram of ST-765SS Series (mm)

IK-765SS Series Free Chlorine or Chlorine Dioxide + pH + Temperature Online Monitoring Panel

The IK-765SS Series is a pre-assembled Free Chlorine or Chlorine Dioxide + pH + Temperature monitoring panel consisting of the ST-765SS-FCL (free chlorine) sensor or ST-765SS-CLO (chlorine dioxide sensor) with mounted FR-50 flow reservoir and the UC-50 Display + Data Logging Terminal. These platform solutions offer real-time display, data logging and signal output capability of sample free chlorine or chlorine dioxide, pH and temperature. The UC-50 is a microprocessor display/data-logging terminal that has been preconfigured to connect Pyxis inline sensors with fully integrated calibration, scaling and measurement protocol. When any Pyxis Lab sensor is connected to the UC-50 in RS-485 Modbus, the UC-50 automatically recognizes the sensor and configuration for immediate data display, data logging and communication. The user may also configure and calibrate the output signal and powered relay through the UC-50 controller's screen. The IK-765SS series detection system can be applied to a potable water piping network, secondary water supply and water quality monitoring of domestic and clean industrial applications.

Item	P/N	Description
IK-765SS-FCL	42082	ST-765SS-FCL Sensor + FR-50 Flow Reservoir + UC-50 Display/Data Logger
IK-765SS-CLO	42085	ST-765SS-CLO Sensor + FR-50 Flow Reservoir + UC-50 Display/Data Logger

Image and Dimensions of IK-765SS Series (mm)

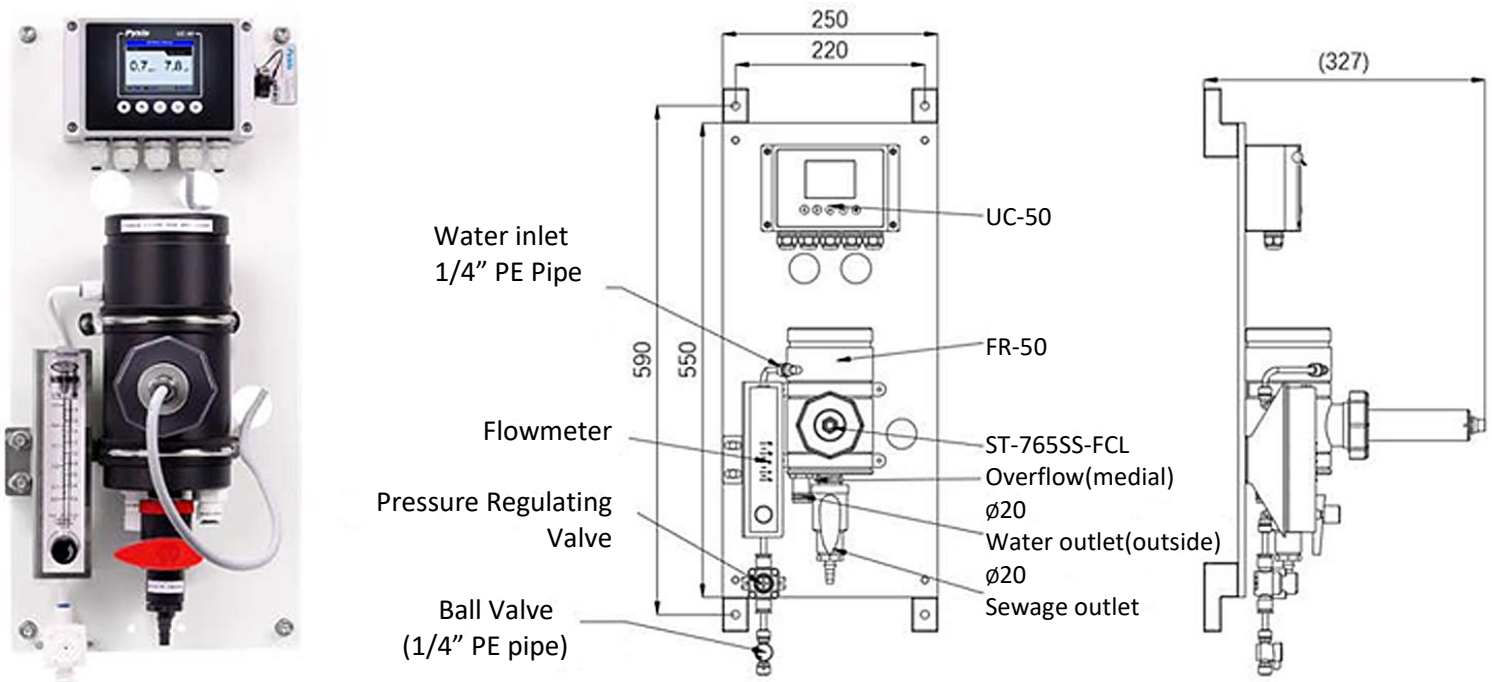
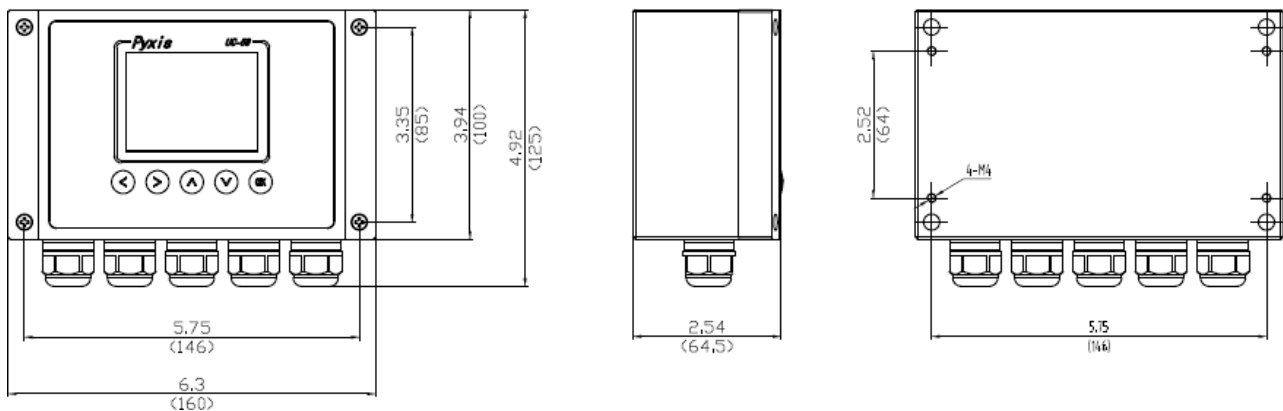

Figure 4 – IK-765SS Series Panel

Specifications of UC-50 Display/Data Logging Terminal

Item	UC-50
P/N	43007
Power	110/220VAC 50/60 Hz, 0.6A
Display	2.8" Color 320 x 240 Resolution
Output	1 x 4-20 mA / RS-485 Modbus-RTU
Input	1 x 4-20 mA / RS-485 Modbus-RTU
Relay Output	One channel relay output – 5Watt Maximum
Data Storage	32 M Flash
USB	1 x USB host for data downloading
Dimension (L x W x D)	6.3 inch x 3.9 inch x 2.6 inch
Weight	4.6 lbs / 2.1 kg
Operation Temperature	32 – 122 °F (-0 – 50 °C)
Storage Temperature	-4 – 158 °F (-20 – 70 °C)
Humidity	5 – 95% No Condensation
Protection	IP-65
BlueTooth	BlueTooth 5.0 - Capable of Reading Pyxis Bluetooth Sensors
Regulation	CE, RoHS

Dimensions of UC-50 (mm/in)



3 Quick 4-20mA Start Up

Follow the wiring table below to connect the ST-765SS series sensor to a controller.

Wire Color	Designation
Red	24 V +
Brown	Power Ground
Green	Shield, solution ground
Gray	4-20 mA -
White	Free Chlorine or Chlorine Dioxide 4-20 mA +
Pink	pH 4-20 mA +
Blue	RS-485 A
Yellow	RS-485 B
Black	Shield, solution ground

NOTE If the 24V power ground and the 4-20 mA-return in the controller are internally connected (non- isolated 4-20mA input), it is unnecessary to connect the 4-20 mA- (Gray wire) to the 4-20 mA negative terminal in the controller. If a separate DC power supplier other than that from the controller is used, make sure that the output from the power supply is rated for 22-26 VDC @ 85mA.

NOTE Pyxis recommends the 24VDC power supply to the ST-765 series sensor be turned OFF for systems that experience extended periods of stagnant water conditions exceeding one hour in duration. Upon sensor power-up, the ST-765 series will complete a 5-minute electrode initialization to remove any oxide layer from the gold electrode which accumulates during stagnation. The sensor will output 1mA for oxidizer/reducer during this initialization process and return to its normal reading with 4-20mA output once complete.

4 Calibration and Diagnosis

The ST-765SS Series sensors are rigorously calibrated before leaving the factory. As such, users do not need to calibrate the sensor for a period of three months or up to one year if the sensor is maintained in clean condition. Users can however calibrate the sensor according to their application needs and as desired using the MA-CR Bluetooth adapter and uPyxis APP for mobile or desktop devices.

4.1 Calibration and Diagnosis by uPyxis Mobile App

Connect and power the ST-765SS sensor using the MA-CR Pyxis Bluetooth adapter (P/N: MA-CR) as shown in the following connection diagram. The power should be sourced from a 24 VDC power terminal of a controller. If a controller is not available, please purchase a 24VDC power supply.



MA-CR Bluetooth Adapter

Display or Controller

8-Pin Sensor

uPyxis Mobile

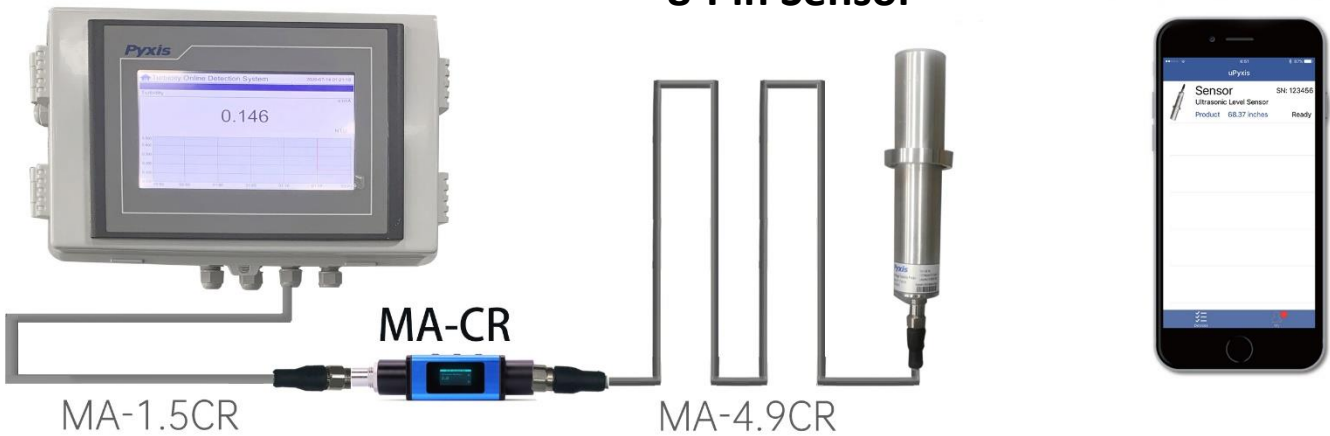

Figure 5. Power the ST-765SS via controller with the MA-CR Bluetooth Adapter inserted between both



Download and install the uPyxis app from **Apple iStore** or **Google Play**. Turn on the Bluetooth in the smart device (please do not pair your device Bluetooth to uPyxis, the app will do the pairing). Open the uPyxis app in the device. Swipe down to refresh the screen to scan the available Pyxis Bluetooth devices. The discovered devices will be listed as shown in *Figure 6*.

Tap the discovered ST-765SS sensor to connect to the sensor. The uPyxis app can identify the sensor type if multiple Pyxis sensors are discovered in the scan.

As shown in *Figure 7*, in the calibration page of uPyxis after connected to the sensor via the MA-CR Bluetooth adapter the current free chlorine or chlorine dioxide, pH and temperature values will be displayed. Six functional tabs of each are available in this page: Zero Calibration, Slope Calibration, pH Low Calibration, pH 7 Calibration, pH High calibration and 4-20mA Span.

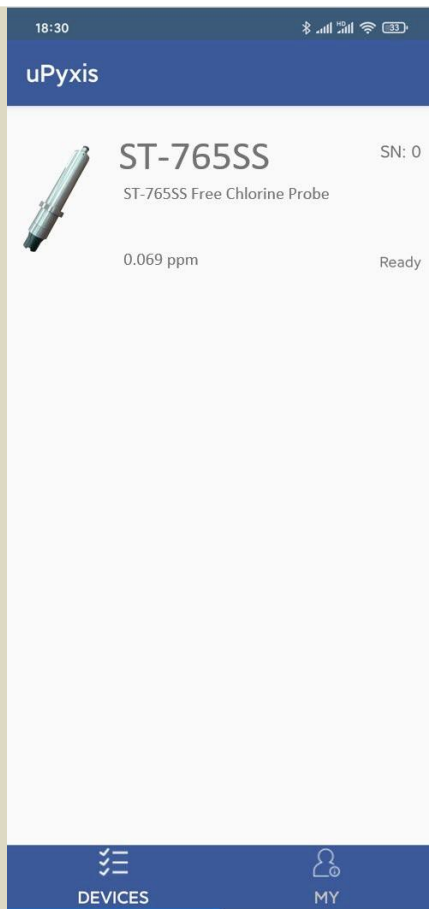

Figure 6. A ST-765SS discovered by Bluetooth scan

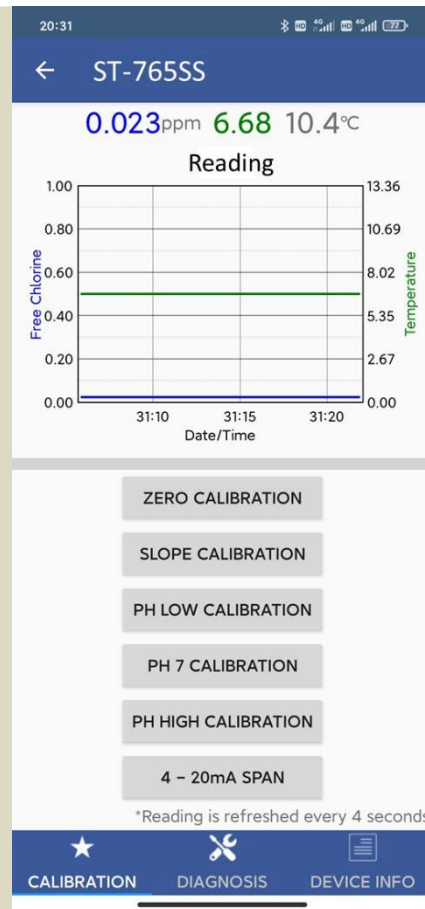

Figure 7. Calibration page

4.1.1 Free Chlorine/ Chlorine Dioxide Calibration

The oxidizer measurement module of ST-765SS Series is rigorously calibrated before leaving the factory. If calibration is required, users can perform single-point or two-point calibration as required. The sensor will measure its specific oxidizer based on model name. ST-765SS-FCL for Free Chlorine and ST-765SS-CLO for Chlorine Dioxide. Each may be respectively calibrated for Zero and Slope Calibration using a known standard / sample tested and measured by DPD wet chemistry methods.

4.1.1.1 Single Point Calibration Procedure

The ST-765SS Series must be slope calibrated in the FR-50 flow reservoir provided with the sensor and must have **CONSISTENT** flow within the specified range of 200 to 4,000mL per minute. Determine the Free Chlorine or Chlorine Dioxide concentration in ppm (mg/L) of the sample water taken from the FR-50 output sample by using the DPD method on the handheld Pyxis SP-200 Oxi-Pocket (P/N 50802) or alternative compliant colorimeter. Launch the uPyxis app and connect to the ST-765SS Series sensor. Tap **SLOPE CALIBRATION**. Enter the free chlorine or chlorine dioxide concentration determined by the DPD method in the dialog window as shown in Figure 6 based on the model sensor you are calibrating. Please make sure that the sensor reading has been stable for at least 10 minutes before calibration. For best results, the concentration of the Free Chlorine and Chlorine Dioxide sample flow standard should be in the range of 0.1 to 5.0 ppm.

4.1.1.2 Two-Point Calibration Procedure

Zero-point Calibration: Launch the uPyxis app and connect to the ST-765SS sensor. Remove the ST-765SS sensor from the FR-50 flow reservoir and place the sensor into a beaker containing Pyxis Zero Chlorine Calibration Standard Solution (P/N 21022), then tap **ZERO CALIBRATION** in the uPyxis app. Please allow sufficient time (a few minutes) for the sensor to stabilize before performing the calibration. ***NOTE*** Users may also use up to 100 us/cm conductivity standard as a ZERO CALIBRATION solution.

Slope-point Calibration: Insert the ST-765SS Series sensor back into the FR-50 flow reservoir and reestablish sample flow. The ST-765SS Series must be slope calibrated in the FR-50 flow reservoir provided with the sensor and must have **CONSISTENT** flow within the specified range of 200 to 400mL per minute. Determine the Free Chlorine or Chlorine Dioxide concentration in ppm (mg/L) of the sample water taken from the FR-50 output sample by using the DPD method on the handheld Pyxis SP-200 Oxi-Pocket (P/N 50802) or alternative compliant colorimeter. Launch the uPyxis app and connect to the ST-765SS Series sensor. Tap **SLOPE CALIBRATION**. Enter the free chlorine or chlorine dioxide concentration determined by the DPD method in the dialog window as shown in Figure 6 based on the model sensor you are calibrating. Please make sure that the sensor reading has been stable for at least 10 minutes before calibration. For best results, the concentration of the Free Chlorine and Chlorine Dioxide sample flow standard should be in the range of 0.1 to 5.0 ppm.

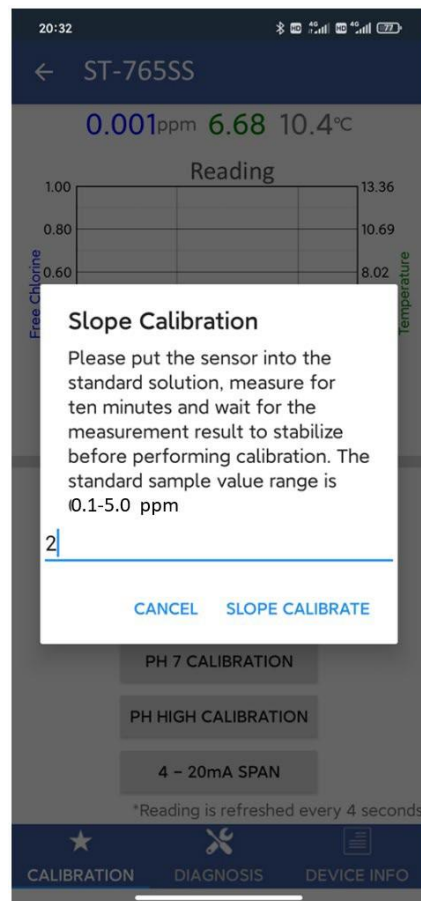

Figure 8 Enter Free Chlorine or Chlorine Dioxide concentration to begin slope calibration

4.1.2 pH Calibration

Remove and place the sensor in a low pH (ie. 4.0) calibration standard solution and tap **pH LOW CALIBRATION** in the uPyxis app. Measure for 1 minute and wait for the measurement result to stabilize before performing calibration, the low pH calibration standard value range acceptable for this step is 1.00-6.00 pH.

Place the sensor into the pH 7.0 calibration standard solution and tap **pH 7 CALIBRATION** in the uPyxis app. Measure for 1 minute and wait for the measurement result to stabilize before performing calibration.

Place the sensor in a high pH (ie. 10.0) calibration standard solution and tap **pH HIGH CALIBRATION** in the uPyxis app. Measure for 1 minute and wait for the measurement result to stabilize before performing calibration, the high pH calibration standard value range acceptable for this step is 8.00-13.00 pH.

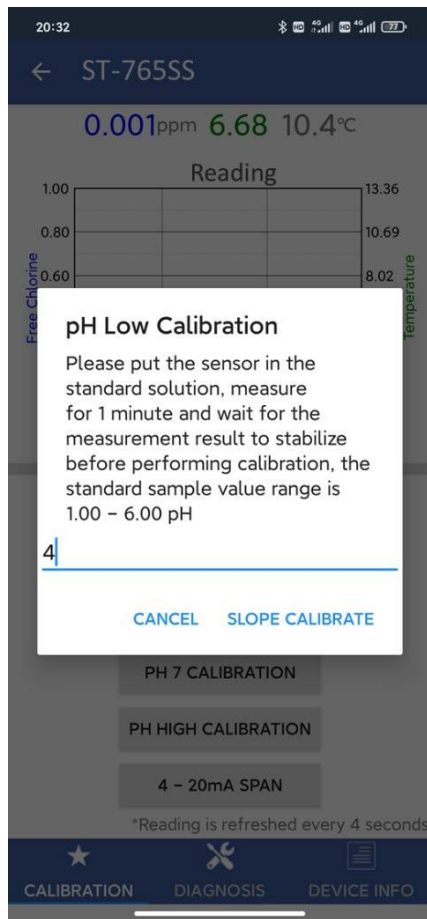

Figure 9 Enter pH concentration to start pH low calibration

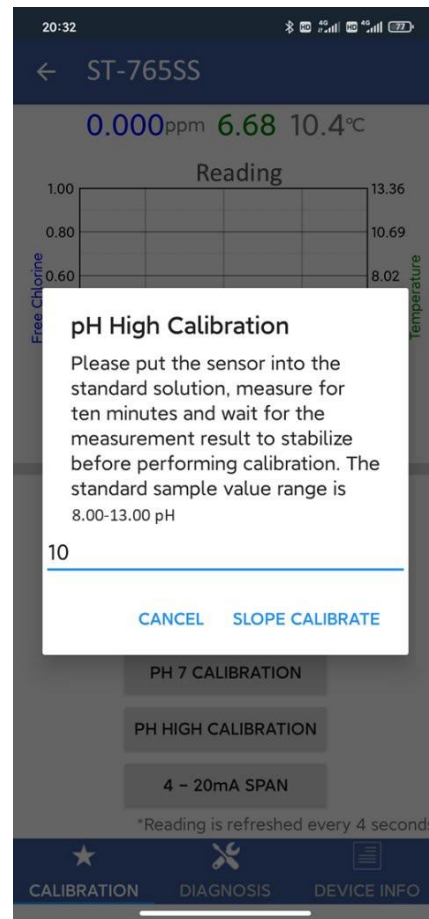

Figure 10 Enter pH concentration to start pH High calibration

4.1.3 4-20mA Span

The default oxidizer 4-20mA span for ST-765SS Series probes is as follows.

- ST-765SS-FCL** 4mA=0ppm Free Chlorine / 20mA = 5ppm Free Chlorine
- ST-765SS-CLO** 4mA=0ppm Chlorine Dioxide / 20mA = 5ppm Chlorine Dioxide

Tap **4-20mA SPAN** to change the free chlorine or chlorine dioxide value corresponding to the 20mA output to a lower value as seen in *Figure 9*. ***NOTE*** The 4-20mA Span feature allows users to REDUCE the upper 20mA output scale only. You cannot INCREASE the upper limit of the sensor beyond the range of the sensor.

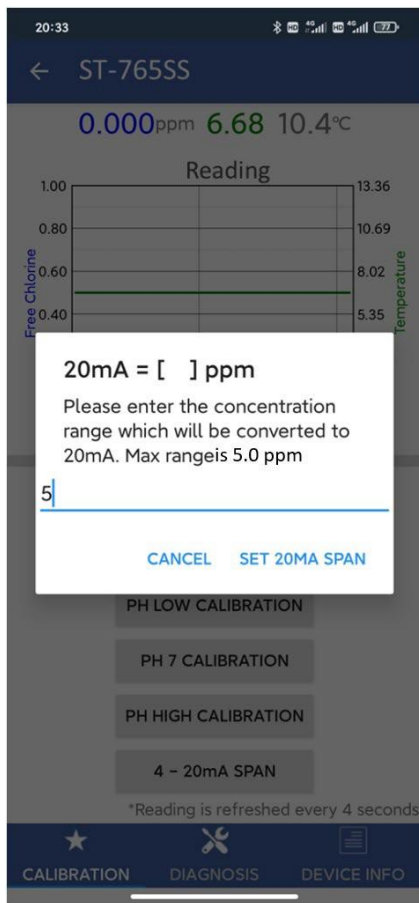

Figure 11 Enter free chlorine concentration to set 4-20mA

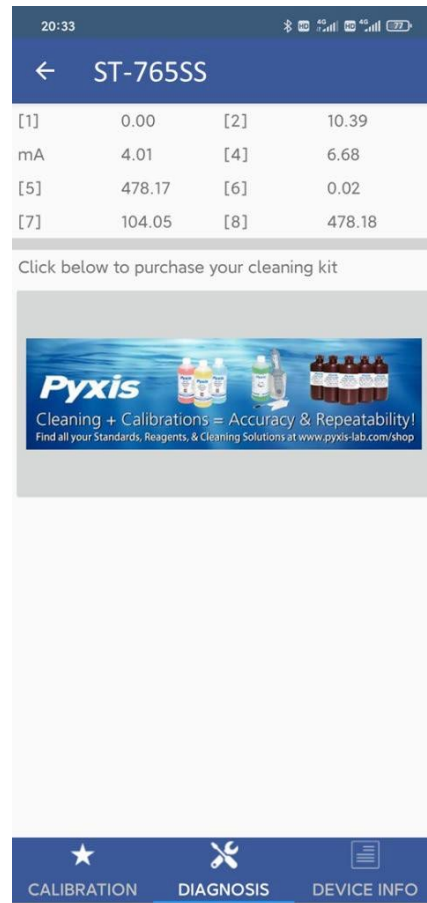

Figure 12 Diagnostic Interface

4.1.4 Diagnosis

Tap **Diagnosis** in the bottom of the app page to launch the diagnosis page *Figure 10*Figure 10.

In this page, the raw data measured by the sensor is displayed. To help troubleshooting possible issues with the sensor, please save images of these data when the sensor is respectively placed in a clean water (tap water or deionized water), in a free chlorine, chlorine dioxide or pH standard solution, and in the sample that the sensor is intended for. This data may be exported from the uPyxis APP via email to service@pyxis-lab.com for technical support.

4.2 Calibration and Diagnosis by uPyxis Desktop App

Download and install uPyxis Desktop APP from

<https://pyxis-lab.com/wp-content/uploads/2021/07/uPyxis.Setup-1.5.18.3-20210714.zip>

Connect and power the ST-765SS Series via a controller and wirelessly communicate with the sensor to a computer via the MA-CR Bluetooth Adapter (P/N: MA-CR) and the USB Bluetooth Adapter for PC (P/N: MA-NEB) according to connection diagram below.



MA-NEB USB Adapter



MA-CR Bluetooth Adapter

Display or Controller

8-Pin Sensor

uPyxis Desktop



Figure 13. Connect the ST-765SS Series sensor wirelessly to a computer via MA-CR Bluetooth and MA-NEB USB adapters

Establish connection between uPyxis APP and the ST-765SS through the following steps:

1. Open the desktop uPyxis APP.
2. Click Device to launch the connection option menu.
3. Select Connect via USB-Bluetooth *Figure 13*.
4. Select the Comm Port to make a connection. Normally only one Comm port is identified by uPyxis *Figure 14*. If more than one Comm port listed in the selection dropdown, you may try to select each one to see if a connection can be made. Alternatively, you may use the Windows Device Manager to identify the Comm Port that the Pyxis USB adapter is using.

After the connection is established, the ST-765SS sensor series number and current conductivity reading will be displayed on the left of the information page *Figure 15*. In this page, a nickname can be assigned to the sensor. The sensor Modbus address can also be changed if desired. Click Calibration to launch the calibration page *Figure 16*.

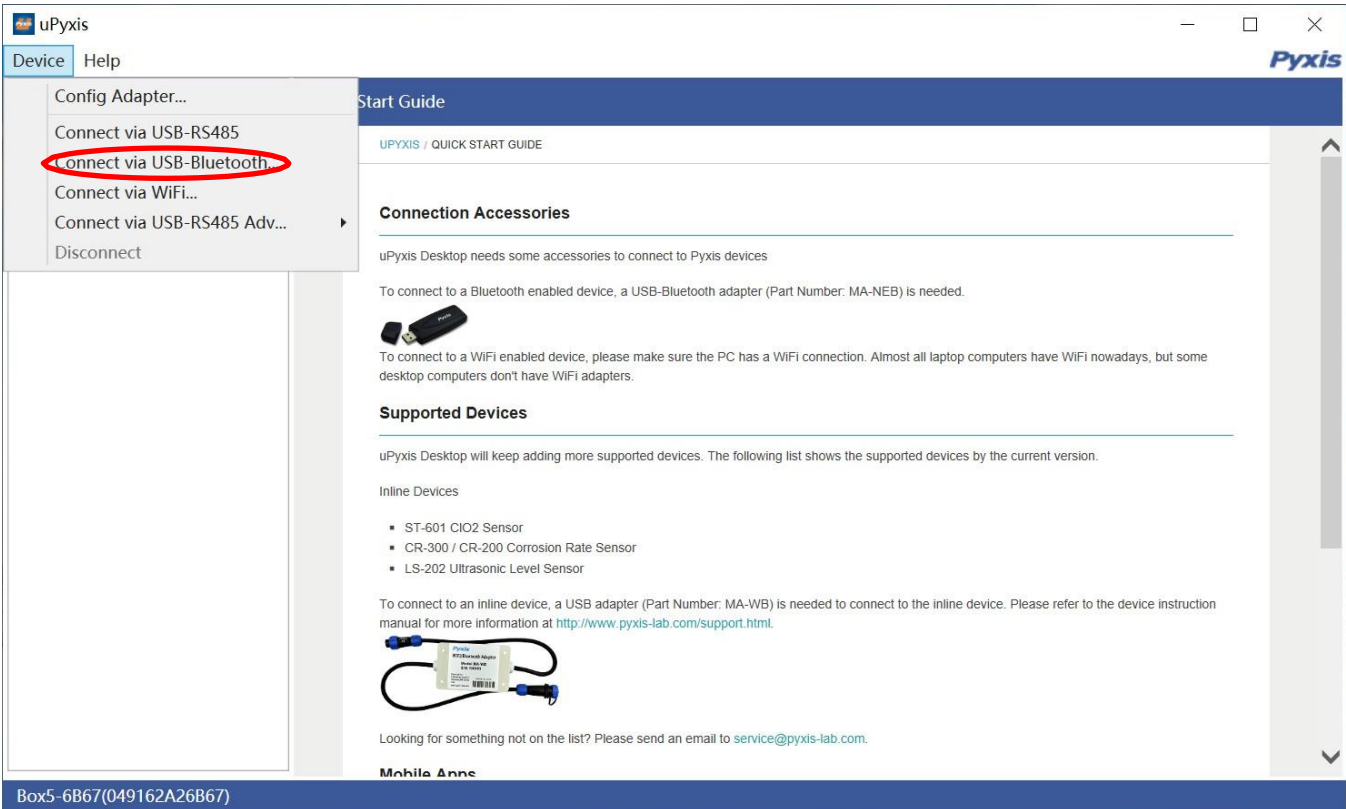

Figure 14. Connection Options

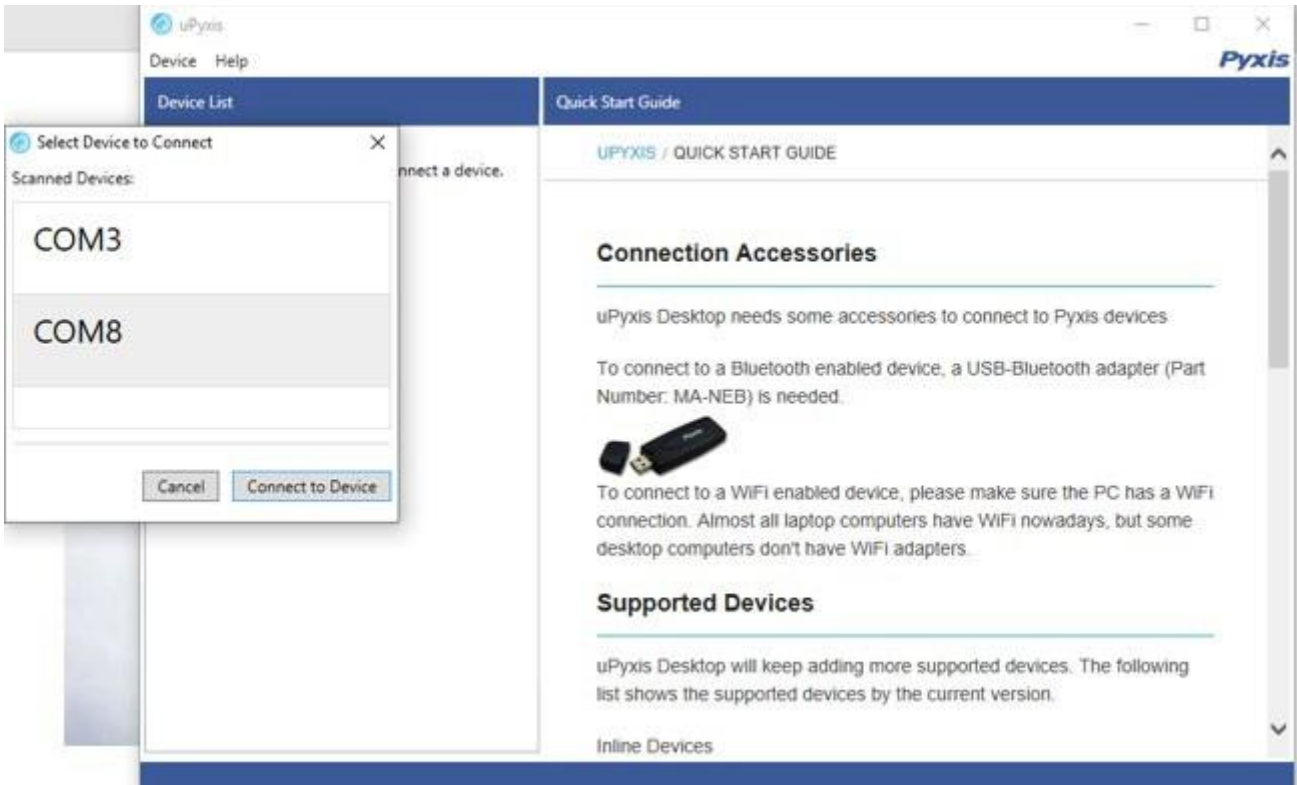

Figure 15. Select a Comm port

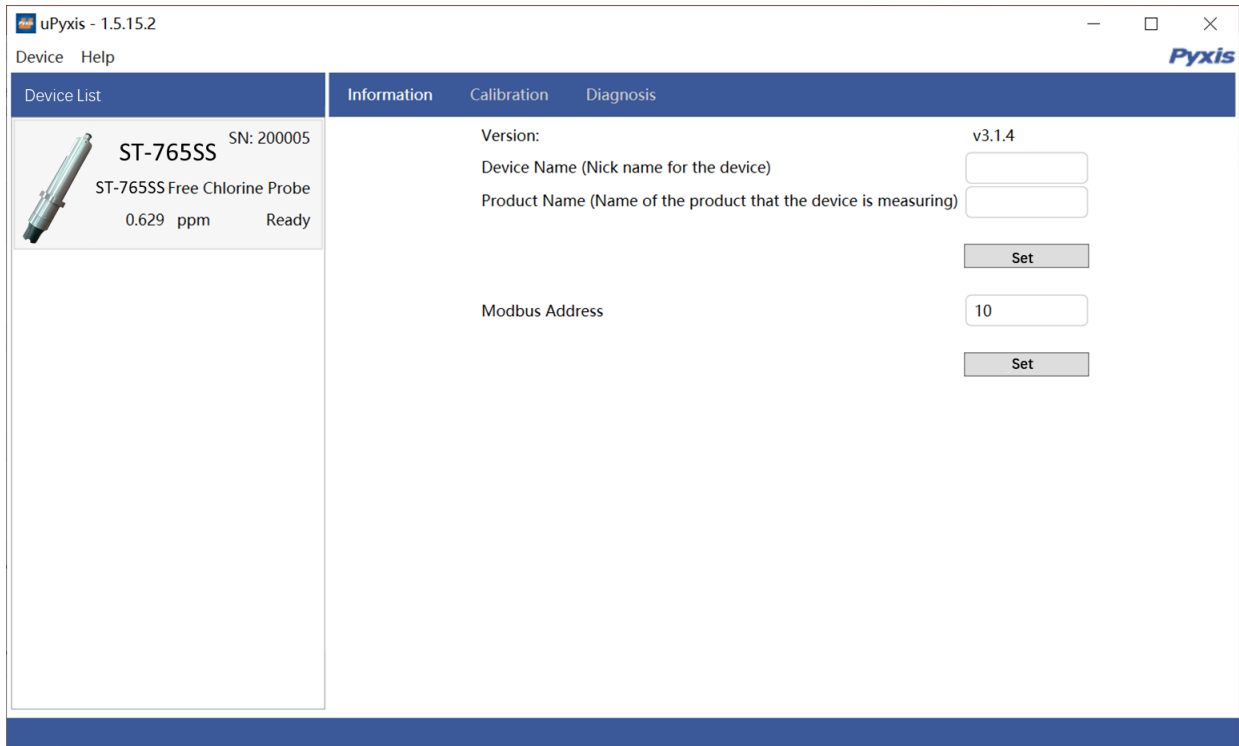

Figure 16. Connected to a ST-765SS sensor and information page

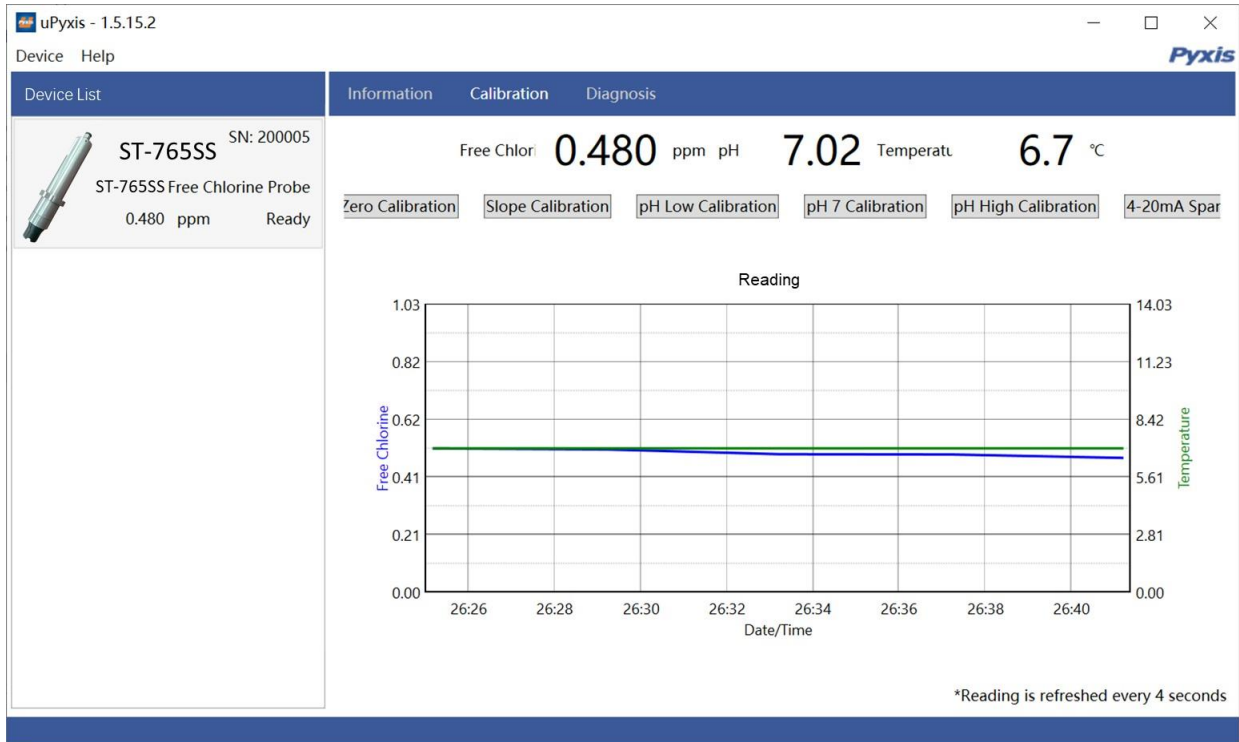

Figure 17. Calibration Page

4.2.1 Free Chlorine/ Chlorine Dioxide Calibration

The oxidizer measurement module of ST-765SS Series is rigorously calibrated before leaving the factory. If calibration is required, users can perform single-point or two-point calibration as required. The sensor will measure its specific oxidizer based on model name. ST-7565S-FCL for Free Chlorine and ST-765SS-CLO for Chlorine Dioxide. Each may be respectively calibrated for Zero and Slope Calibration using a known standard / sample tested and measured by DPD wet chemistry methods.

4.2.1.1 Single Point Calibration Procedure

The ST-765SS Series must be slope calibrated in the FR-50 flow reservoir provided with the sensor and must have **CONSISTENT** flow within the specified range of 200 to 400mL per minute. Determine the Free Chlorine or Chlorine Dioxide concentration in ppm (mg/L) of the sample water taken from the FR-50 output sample by using the DPD method on the handheld Pyxis SP-200 Oxi-Pocket (P/N 50802) or alternative compliant colorimeter. Launch the uPyxis app and connect to the ST-765SS Series sensor. Tap **SLOPE CALIBRATION**. Enter the free chlorine or chlorine dioxide concentration determined by the DPD method in the dialog window as shown in Figure 6 based on the model sensor you are calibrating. Please make sure that the sensor reading has been stable for at least 10 minutes before calibration. For best results, the concentration of the Free Chlorine and Chlorine Dioxide sample flow standard should be in the range of 0.1 to 5.0 ppm.

4.2.1.2 Two-Point Calibration Procedure

Zero-point Calibration: Launch the uPyxis app and connect to the ST-765SS sensor. Remove the ST-765SS sensor from the FR-50 flow reservoir and place the sensor into a beaker containing Pyxis Zero Chlorine Calibration Standard Solution (P/N 21022), then tap **ZERO CALIBRATION** in the uPyxis app. Please allow sufficient time (a few minutes) for the sensor to stabilize before performing the calibration. ***NOTE*** Users may also use up to 100 us/cm conductivity standard as a ZERO CALIBRATION solution.

Slope-point Calibration: Insert the ST-765SS Series sensor back into the FR-50 flow reservoir and reestablish sample flow. The ST-765SS Series must be slope calibrated in the FR-50 flow reservoir provided with the sensor and must have **CONSISTENT** flow within the specified range of 200 to 400mL per minute. Determine the Free Chlorine or Chlorine Dioxide concentration in ppm (mg/L) of the sample water taken from the FR-50 output sample by using the DPD method on the handheld Pyxis SP-200 Oxi-Pocket (P/N 50802) or alternative compliant colorimeter. Launch the uPyxis app and connect to the ST-765SS Series sensor. Tap **SLOPE CALIBRATION**. Enter the free chlorine or chlorine dioxide concentration determined by the DPD method in the dialog window as shown in Figure 6 based on the model sensor you are calibrating. Please make sure that the sensor reading has been stable for at least 10 minutes before calibration. For best results, the concentration of the Free Chlorine and Chlorine Dioxide sample flow standard should be in the range of 0.1 to 5.0 ppm

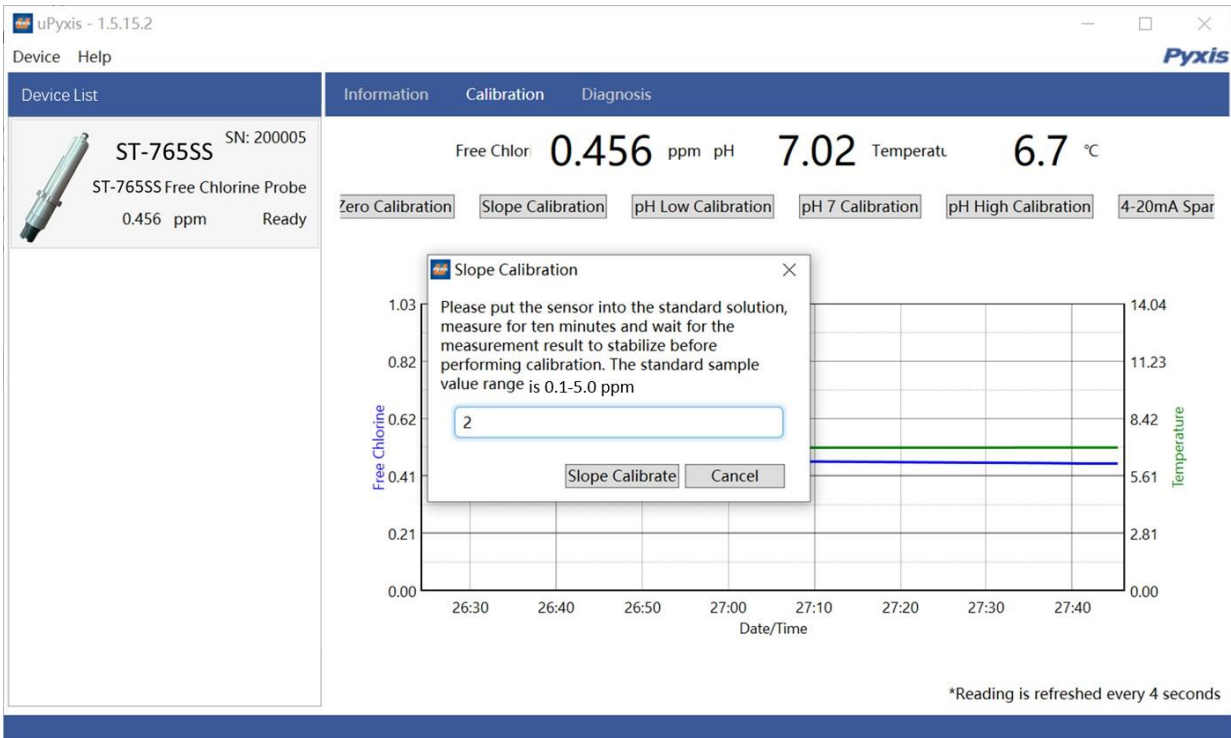

Figure 18 Slope Calibration

4.2.2 pH Calibration

Remove and place the sensor in a low pH (ie. 4.0) calibration standard solution and tap **pH LOW CALIBRATION** in the uPyxis app. Measure for 1 minute and wait for the measurement result to stabilize before performing calibration, the low pH calibration standard value range acceptable for this step is 1.00-6.00 pH.

Place the sensor into the pH 7.0 calibration standard solution and tap **pH 7 CALIBRATION** in the uPyxis app. Measure for 1 minute and wait for the measurement result to stabilize before performing calibration. Place the sensor in a high pH (ie. 10.0) calibration standard solution and tap **pH HIGH CALIBRATION** in the uPyxis app. Measure for 1 minute and wait for the measurement result to stabilize before performing calibration, the high pH calibration standard value range acceptable for this step is 8.00-13.00 pH.

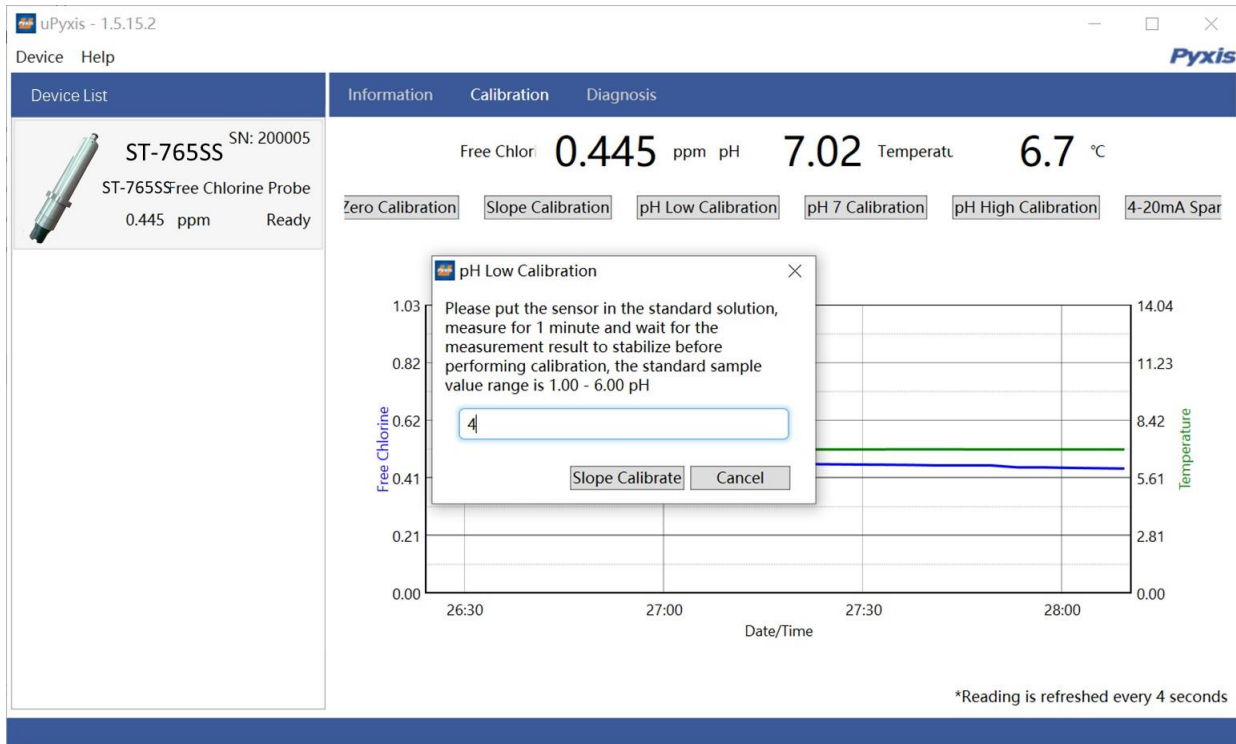

Figure 19 pH Low Calibration

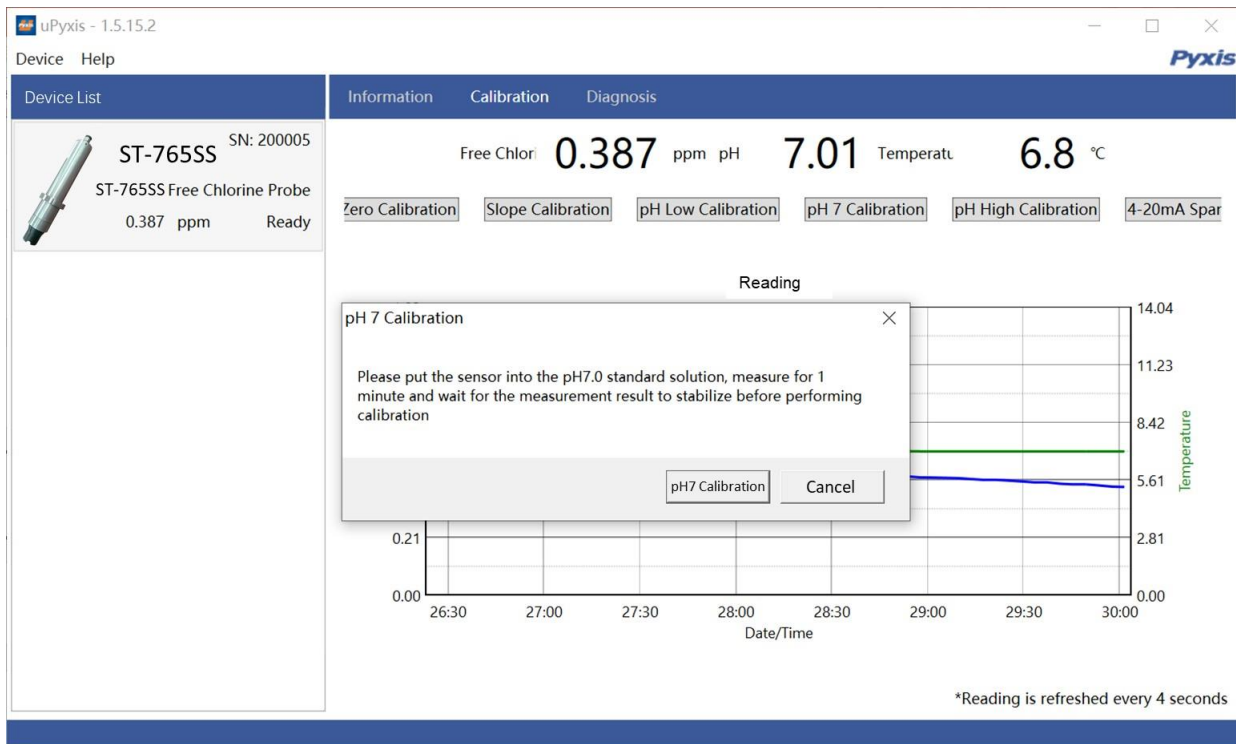

Figure 20 pH 7 Calibration

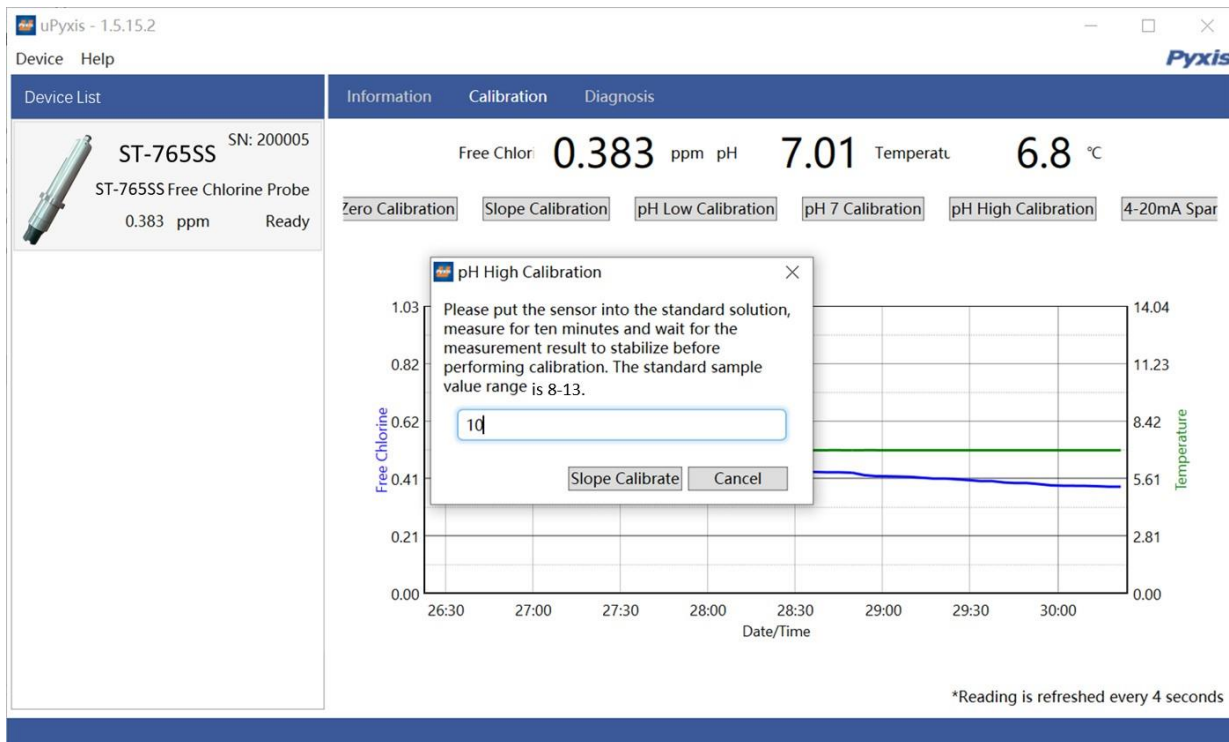

Figure 21 pH High Calibration

4.2.3 4-20mA Span

The default oxidizer 4-20mA span for ST-765SS Series probes is as follows.

ST-765SS-FCL 4mA=0ppm Free Chlorine / 20mA = 5ppm Free Chlorine

ST-765SS-CLO 4mA=0ppm Chlorine Dioxide / 20mA = 5ppm Chlorine Dioxide

Tap **4-20mA SPAN** to change the free chlorine or chlorine dioxide value corresponding to the 20mA output to a lower value as seen in *Figure 20*. ***NOTE*** The 4-20mA Span feature allows users to REDUCE the upper 20mA output scale only. You cannot INCREASE the upper limit of the sensor beyond the range of the sensor.

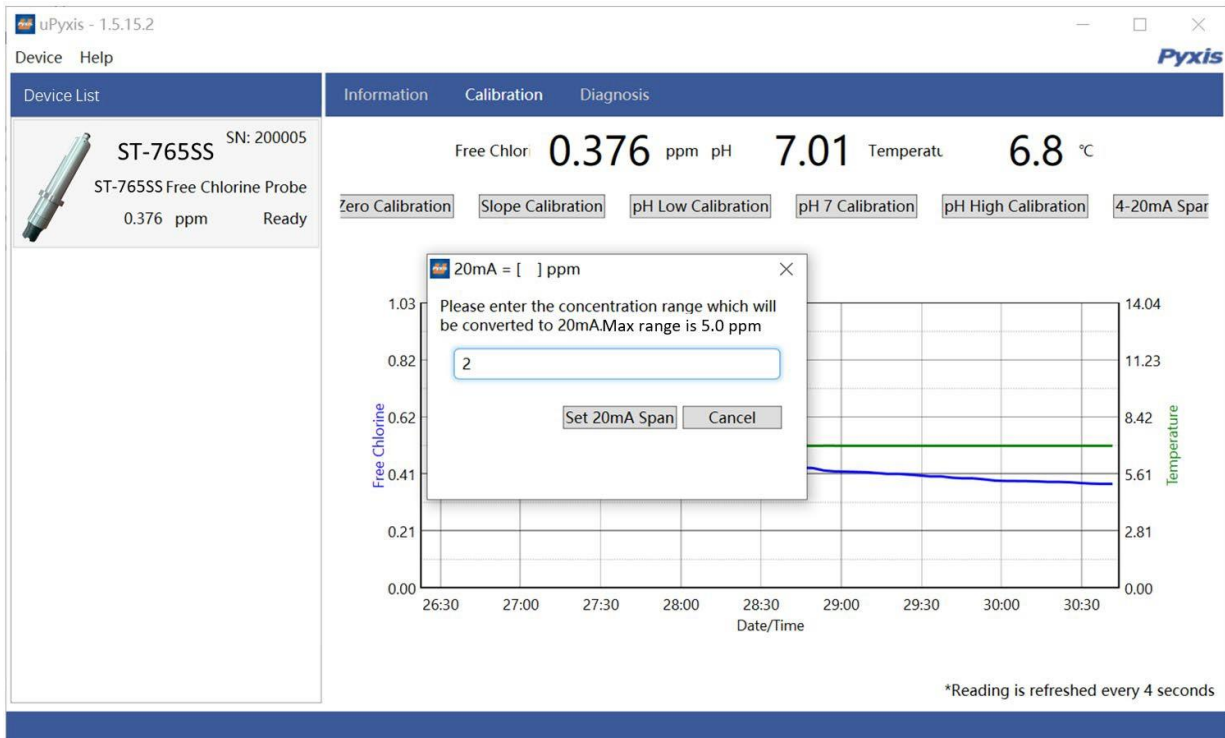

Figure 22 Set 4-20mA Span

4.2.4 Diagnosis

Tap **Diagnosis** in the bottom of the app page to launch the diagnosis page *Figure 22*.

In this page, the raw data measured by the sensor is displayed. To help troubleshooting possible issues with the sensor, please save images of these data when the sensor is respectively placed in a clean water (tap water or deionized water), in a free chlorine or pH standard solution, and in the sample that the sensor is intended for. This data may be exported from the uPyxis APP via email to service@pyxis-lab.com for technical support.

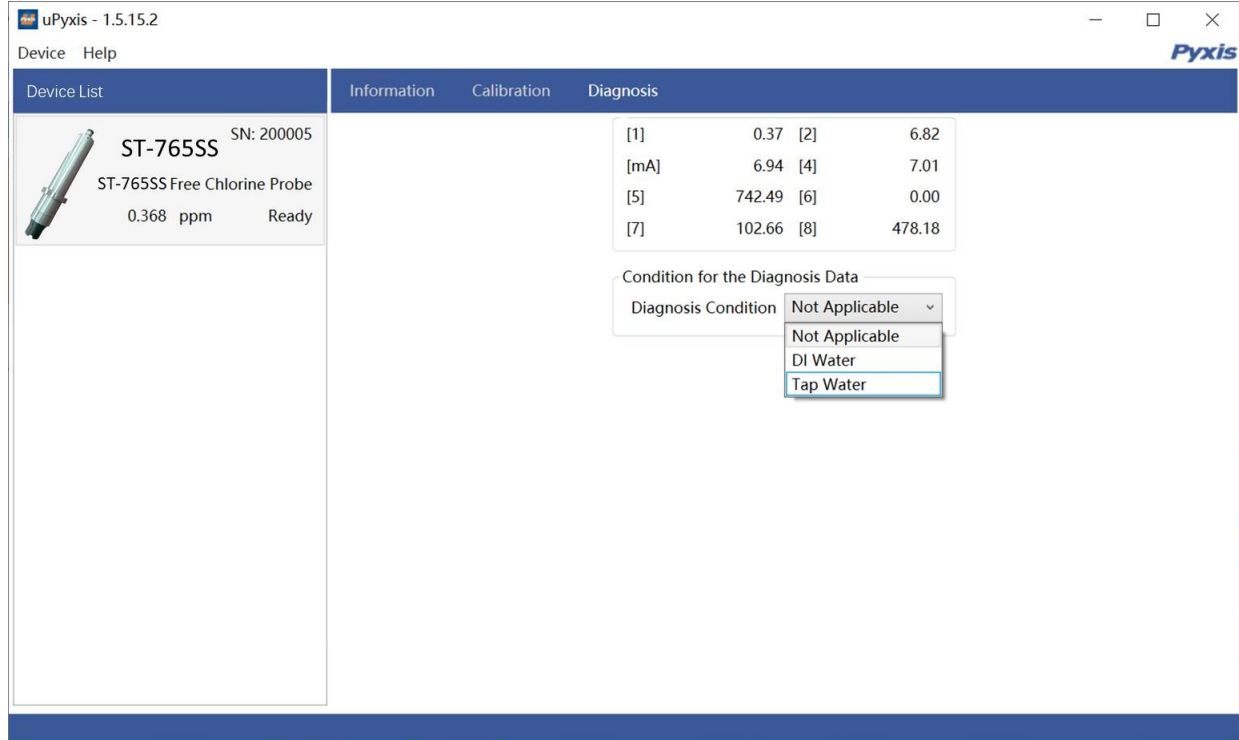

Figure 23 Diagnostic Interface

4.3 Calibration on the Controller

It is recommended that the ST-765SS Series calibration be carried out using the uPyxis app as demonstrated in the sections above. Alternatively, a single point calibration can be carried on the controller by adjusting the mA-to-ppm ratio (free chlorine or chlorine dioxide). However, if calibration is to be performed via the controller, it must be cleaned with deionized water prior to calibration, taking care to avoid direct hand contact with the electrodes. Please follow the controller manufacturer's procedures for 4-20mA calibration as with any sensor. With the default sensor settings, the controller should be set to convert 4 mA to 0 ppm and 20 mA to 5.00 ppm for both ST-765SS-FCL and ST-765SS-CLO.

For single calibrations involving the sample water itself, use the Pyxis SP-200 (Portable Water Multimeter) to determine the DPD free chlorine or chlorine dioxide concentration of the active sample water obtained from the FR-50 flow reservoir outlet sample line.

5. Modbus RTU

The ST-765SS Series sensors are configured as a Modbus slave device. In addition to the ppm free chlorine or chlorine dioxide values, many operational parameters, including warning and error messages, are available via a Modbus RTU connection.

Contact Pyxis Lab Customer Service (service@pyxis-lab.com) for more information.

6. Sensor Cleaning and Maintenance

Soak the lower half of the sensor in 100 mL inline sensor cleaning solution for 10-15 minutes. Gently rub the sensor electrode head with the provided Q-tips. If the surface is not entirely clean, continue to soak the sensor for an additional time until clean. Rinse the sensor with distilled water. Pyxis Lab Inline Sensor Cleaning Solution can be purchased at our online Estore/Catalog at <https://pyxis-lab.com/product/probe-cleaning-kit/>



Figure 24 ST-Series Probe Cleaning Kit (P/N SER-01)

6.1 Other Common Troubleshooting Issues

If the ST-765SS sensor output signal is not stable and fluctuates significantly, make an additional solution ground connection—connect the black ground wire to a conductor that contacts the sample water electrically such as a brass pipe adjacent to the ST-765SS.

7 Replacing pH and Oxidizer Electrode Head

The pH/oxidizer electrode head of ST-765SS Series can be replaced when the original electrode head reaches its working life. Order a replacement electrode head EH-765 (P/N 53061) from Pyxis and follow instructions as below.

1. Turn off the sensor if it is powered on.
2. Make sure there is no water on the sensor.
3. Hold the ST-765SS main body with one hand and use the other hand to twist the stainless-steel locking ring counter-clockwise until the front end of the black electrode is completely unscrewed, as shown in *Figure 25-2*.
4. Pull out the electrode head as shown in *Figure 25-3*.
5. Loosen the electrode plug connector, and remove the electrode head, as show in *Figure 25-4*.
6. To assemble the new electrode head, connect the plug, then insert the new electrode head into the main sensor housing and ensure that the two protrusions on the electrode head are aligned with the notches in the sensor main housing.
7. Then twist the stainless-steel lock ring of ST-765SS in a clockwise direction until the threads of the electrode head completely enter the ST-765SS housing as shown in *Figure 25-1*.

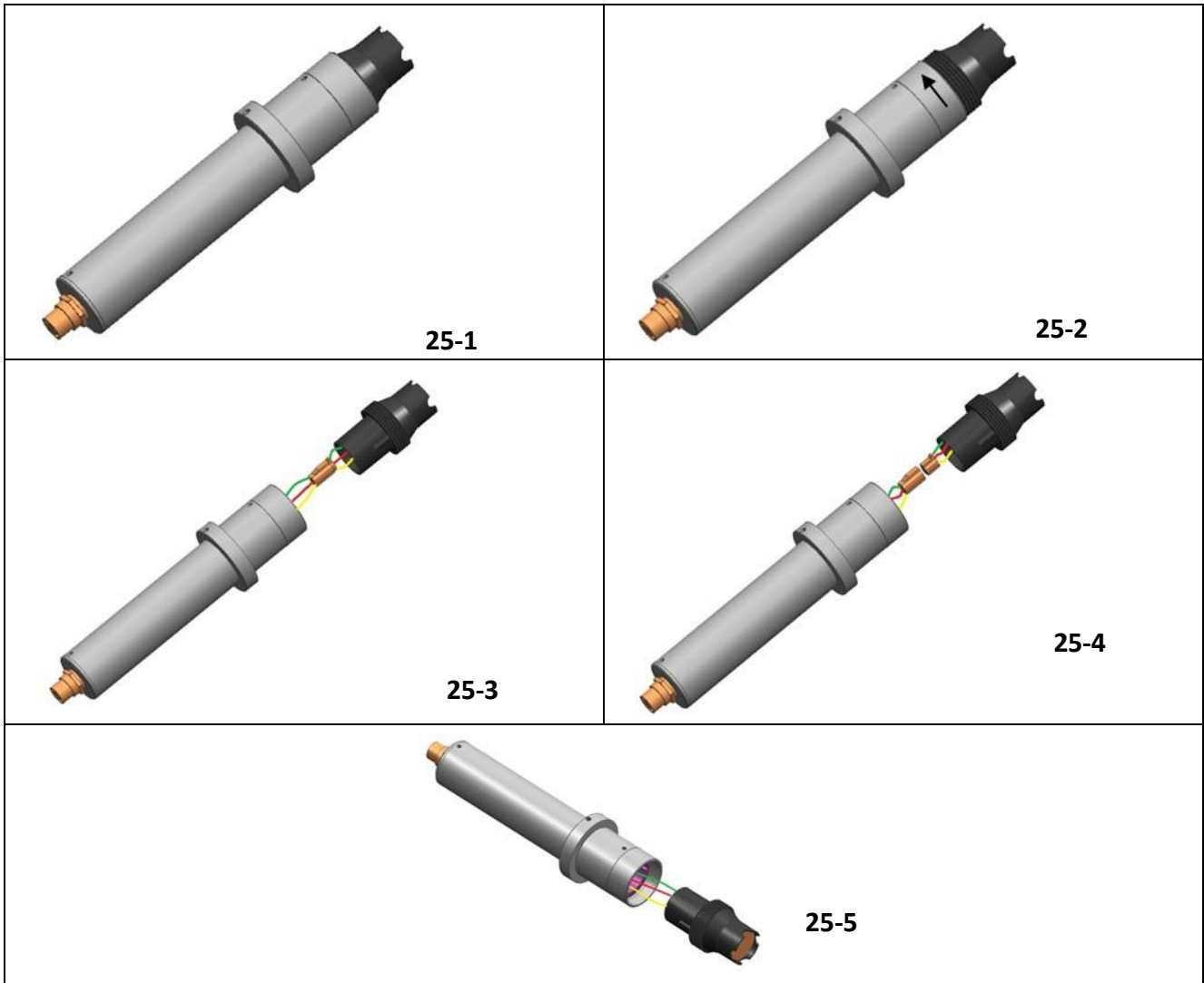

8 Contact Us

Pyxis Lab, Inc
1729 Majestic Dr. Suite 5
Lafayette, CO 80026 USA
www.pyxis-lab.com
Phone: +1 (866) 203-8397
Email: service@pyxis-lab.com